

Burford®

Bag Requirements

Burford® Tyers

Bag Thickness Requirements:

Bag thickness and plastic composition will affect closure quality differently for individual products. A minimum bag thickness of 1.25 mils is recommended for optimal performance. Contact your Burford® Salesperson for custom applications.

Note: Bag tail presentation from the exit of a bagger must be as even and straight as possible for consistent product quality. If this is not achievable, contact your Bagger manufacturer for assistance.

X = DIAGONAL
Y = BAG NECK LENGTH

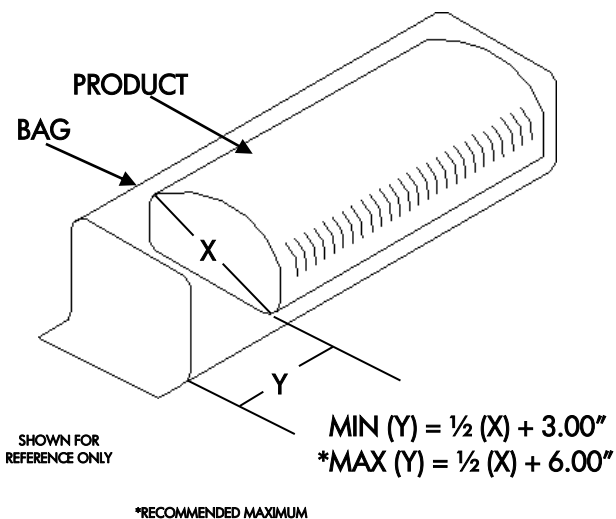

Bag Neck Length Requirements:

Measure the diagonal across the end of the product.

Take one-half of the diagonal measurement and add a minimum of 3 inches to determine the required length of the bag neck.

This formula should be used to confirm your bag neck length requirements for existing applications or to assist in calculating a bag neck length for new product development. Please consult a reliable package manufacturer for your specific needs or contact Burford® Corp. if we can be of assistance.

Note: Short bag neck lengths may cause excessive ribbon drops and package jams.

PRACTICAL SOLUTIONS THROUGH INNOVATIVE TECHNOLOGIES



CALL US TODAY 1-877-BURFORD (287-3673)